

TTC Floorunits – Heating, Cooling, Ventilating
Planning Documentation
for Engineers and Plant Contractors

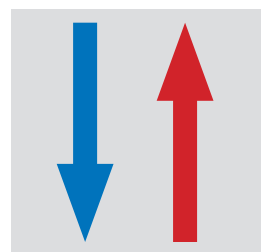

Contents | Features

Convective and Dynamic TTC Floor Units



General Information

Pages 4–7

- Order key for TTC Floor Units
- Notes on air conditioning
- TTC Floor Unit series and features
- Application examples for TTC air conditioning components
- Gratings, mitred corners and mitred ends, measurement

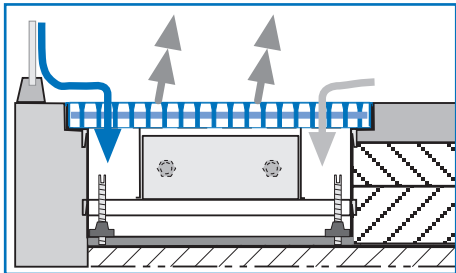

TTC Floor Unit FHOK2.17 and FHOK2.24

Pages 8–9

- **Operation:** Heating mode for selective and full heating (2 pipe system)
- 2 unit depths (170 mm and 240 mm)
- 6 unit lengths from 900 mm to 2400 mm in 300 mm increments
- Installation in lime floors or raised floors
- Unit heights from 90 mm, depending on the grating used
- Housing and heat exchanger coated black
- Special designs on request

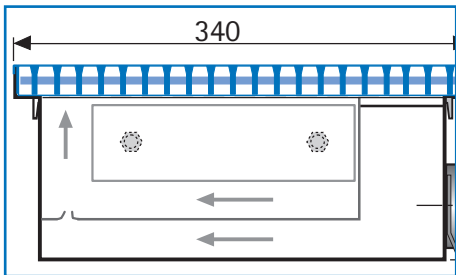

TTC Floor Unit FHKI

Pages 10–11

- **Operation:** Induction unit for heating and/or cooling mode
- Available as a 2 or a 4 pipe system
- Unit depth 340 mm
- Unit length 1200 mm
- To be used in conjunction with a ventilation system
- Installation in raised floors
- Unit heights from 163 to 182 mm, depending on the grating used
- Housing and heat exchanger coated black

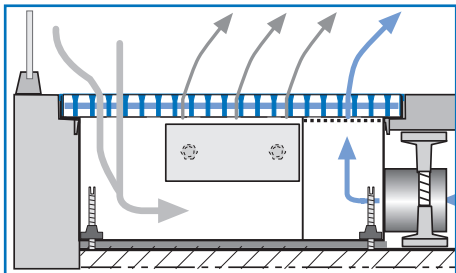

TTC Floor Unit FHOQ

Pages 12–13

- **Operation:** Displacement air unit for heating and cooling mode (cooling with displacement air)
- 2 pipe system for heating mode
- Unit depths 240 and 340 mm
- Unit lengths 900 to 2400 mm in 300 mm increments
- To be used in conjunction with a ventilation system
- Installation in raised floors only
- Unit heights from 130 mm, depending on the grating used
- Housing and heat exchanger coated black
- Special designs on request

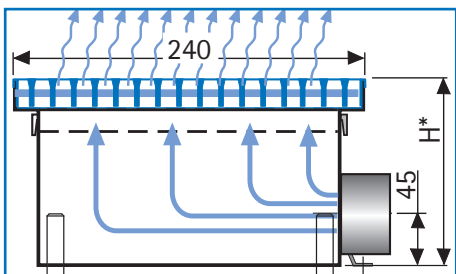

TTC Floor Unit FOOQ

Page 14

- **Operation:** Displacement air distribution channel
- Unit depths 240 or 340 mm
- Unit length 900 to 2400 mm in 30 cm increments
- To be used in conjunction with a ventilation system
- Installation in raised floors only
- Unit heights from 130 mm, depending on the grating used
- Housing and heat exchanger coated black
- Special designs on request

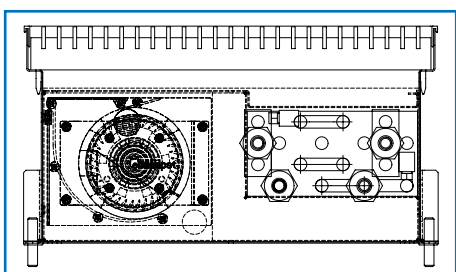

TTC Floor Unit FHKV

Pages 15–19

- **Operation:** Ventilation system supported heating and/or cooling
- Available as a 2 pipe or a 4 pipe system
- Unit depth 340 mm
- Unit lengths 1250 to 2750 mm
- Installation in lime or raised floors
- Unit heights from 150 to 180 mm, depending on the grating used
- Housing and visible heat exchangers coated black
- Special designs on request

Order Key for Floor Units

Order Key for TTC FHKV Series Floor Units

FHKV 4.34.125LAN

Grating colours

N = Natural coloured, anodised aluminium R = Untreated V2A special steel
P = Powder coated in special RAL colour D = Polished V2A special steel

Grating materials

A = Aluminium
V = V2A special steel

Grating types

L = Longitudinal grating, rigid (free air passage 77–88%)
K = Comb grating, rigid (free air passage 77–87%)
Q = Cross grating, flexible (free air passage 65–80%)
R = Roll grating

Unit length L_{tot} [mm]

L_{tot} 0900 – 1200 – 1500 – 1800 – 2100 – 2400 mm
 L_{tot} (FHKV) 1250 – 1750 – 2250 – 2750 mm

Unit depth [mm]

170 – 240 – 340 other unit depths on request

Heat exchanger

2 = 2 pipe system 4 = 4 pipe system (for FHKV and FHKI only)

Floor Unit series

FHOK Floor Unit series, heating with free convection
FHKI Floor Unit series, heating + cooling + ventilation, with induction
FHOQ Floor Unit series, heating + displacement air
FOOQ Floor Unit series, displacement air
FHKV Floor Unit series, heating + cooling, ventilation system supported
FHKVZ Floor Unit series, heating + cooling, ventilation system supported + primary air connection

Floor trench heights for different grating types

Floor Unit-series	Grating designs Floor Unit height [mm]					
	LSF20.03	LST18.06	KST18.06	KSF18.06	QFT18.06	QFT20.03
FHOK	108	106	125	125	106	108
FHKI	162	160	179	179	160	162
FHOQ	132	130	149	149	130	132
FOOQ	132	130	149	149	130	132
FHOV	108	106	125	125	106	108
FHKV	152	150	180	180	150	152

4.1

© 2010 TTC Timmler Technology GmbH

This document or any part thereof may not be reprinted, copied, or translated and figures and diagrams may not be used without prior permission in writing from TTC Timmler Technology GmbH.



General Information

Thermal comfort

Rooms with high windows or cold encapsulating walls can have a negative influence on the thermal comfort of the people who occupy such rooms. However, feeling comfortable in your environment is a critical factor for your efficiency. The German standard DIN 1946/Part 2 describes the criteria for thermal comfort. We would like to briefly state the most important criteria.

1. Cold radiation (radiation draught)

Heat sources always radiate their energy in the direction of cooler areas. This energy transfer is dependent on the temperature difference Δt . The higher the Δt , the higher is the energy flow. Hence, cold areas of the room (windows, walls) act as cold radiators. We feel this effect as a draught which is known as the radiation draught. It does have a negative effect on our thermal comfort (see Fig. 5.1).

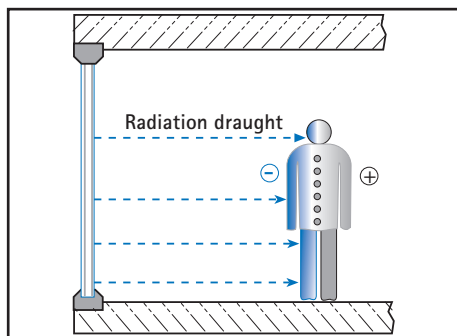

5.1

2. Cold air flows

Air cools off on cold windows or walls and due to its higher density sinks to the floor where it forms a cold air pocket just above floor level. This cold air pocket can penetrate the room with air speeds of up to 0.5 m/s. It is this air movement that people experience as being very unpleasant. The temperature gradient will rise (see Fig. 5.2).

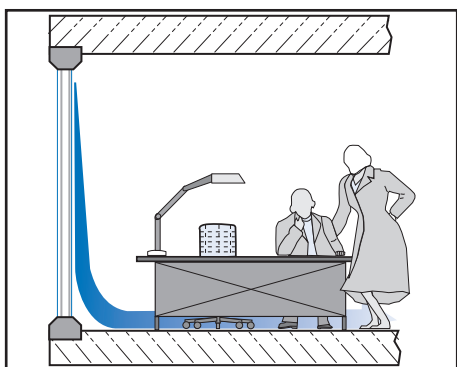

5.2

3. Room air condensation

Low surface temperatures on windows and outer walls, compared with the warmer air inside the room, often lead to condensation being formed. How much condensation is formed depends on the temperature difference between the surface and the room air temperature as well as the relative humidity. TTC Floor Units can prevent condensation.

Is ventilation necessary?

The German standard DIN 1946/Part 2/Chapter 3.2 demands pre-conditioned outside air rates for enclosed spaces if people are working in such spaces. Hence, ventilation is always required. In addition, the central ventilation system will also remove the latent cooling percentage (humidity) and any smells from the rooms.

The solution: TTC Floor Units

To help you to meet the above requirements TTC Timmler Technology GmbH has designed a number of products. Operation and application of these products will be explained in detail in this planning document.

For other products in our range such as TTC Chilled Beams and TTC Cooling Units please see the relevant planning documentation.

Operation of TTC Floor Units

TTC Floor Units are connected to the hot water supply. As they are positioned in front of cold surfaces around the perimeter of a room and because heat rises convectively they create an air circulation, that can (see Fig. 5.3),

- prevent cold radiation,
- prevent cold air entering the room and
- heat rooms.

Products of the FHKV, FHKI, FHOQ and FOOQ series can, depending in which type you select, also be used for cooling and ventilation purposes.

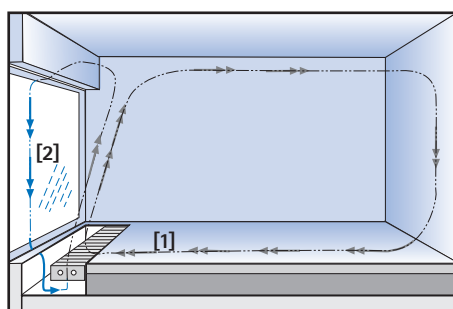

5.3 [1] Warm air circulation [2] Cold air sinking down

Important!

The series in Fig. 5.4–5.8 are suitable for mixed application. However, please ensure that all units used are of the same unit depth.

Types and Operation

FHOK series

Heating mode with free convection

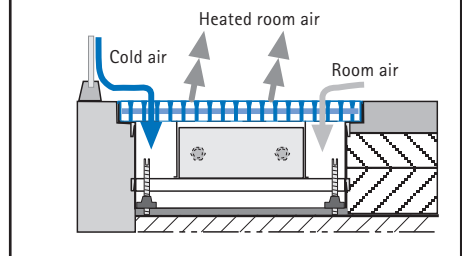

5.4

FHKI series

Heating and cooling mode with induction

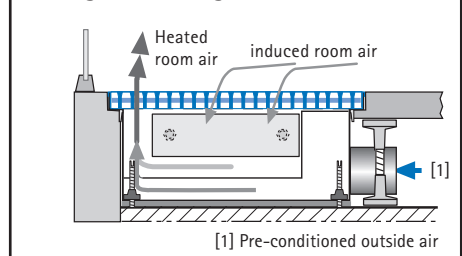

5.5

FHOQ series

Heating mode and displacement air

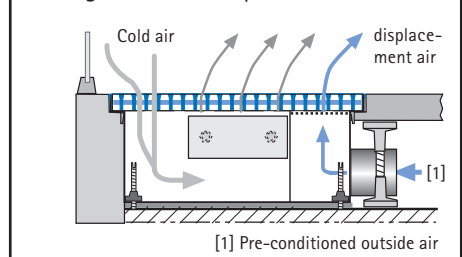

5.6

FOOQ series

Displacement air mode

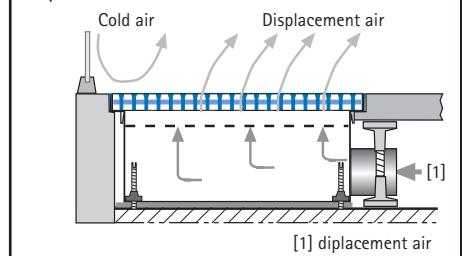

5.7

FHKV series

Heating and cooling mode with ventilation system support

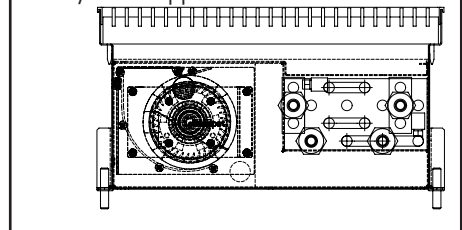

5.8

Products in Use | Examples

Air conditioning a room using a TTC Cooling Unit, a TTC Floor Unit and TTC Air Passage Grills

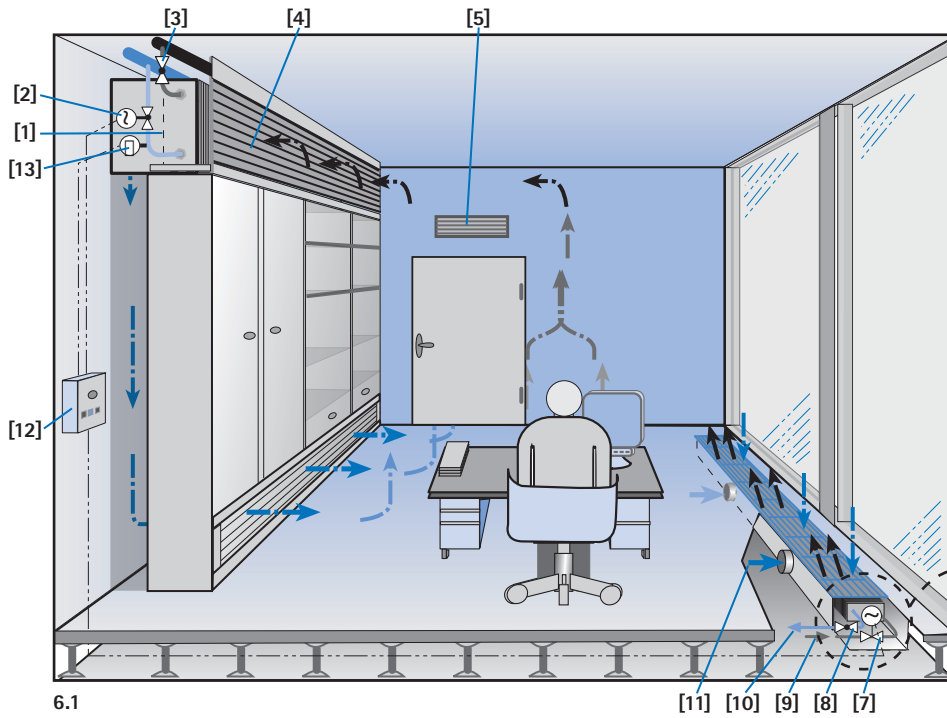

TTC Products used:

- [1] TTC Cooling Unit on top of a cupboard
- [2] Valve with electrothermic actuator, cooling
- [3] Water return connection
- [4] TTC Air Inlet Grill for cooling unit
- [5] TTC Air Outlet Grill for escaping air
- [6] TTC Floor Unit FHOQ (heating)
- [7] Valve with electrothermic actuator, heating
- [8] Water return valve
- [9] Warm water supply
- [10] Warm water return
- [11] Displacement air connection (outside air/supply air)
- [12] Temperature control
- [13] Dew sensor in the chilled beam on the water supply

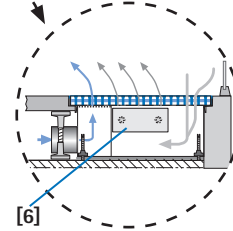

Air conditioning a room using TTC Chilled Beams, TTC Floor Units and TTC Air Passage Grills

TTC products used:

- [1] Active TTC Chilled Beam, e. g. ACBLE, in panelled ceiling with supply air connection
- [2] Supply air channel for outside air
- [3] Dew sensor on the cold water supply
- [4] Cold water control valve
- [5] Cold water supply and +[6] cold water return
- [7] TTC Air Outlet Grill for escaping air
- [8] Temperature control
- [9] Warm water return
- [10] Warm water supply
- [11] Water return valve
- [12] Valve with electrothermic actuator
- [13] TTC Floor Unit FHOK for heating mode

Note:

For more information on TTC Chilled Beams please ask for our detailed planning documentation for engineers and plant contractors.

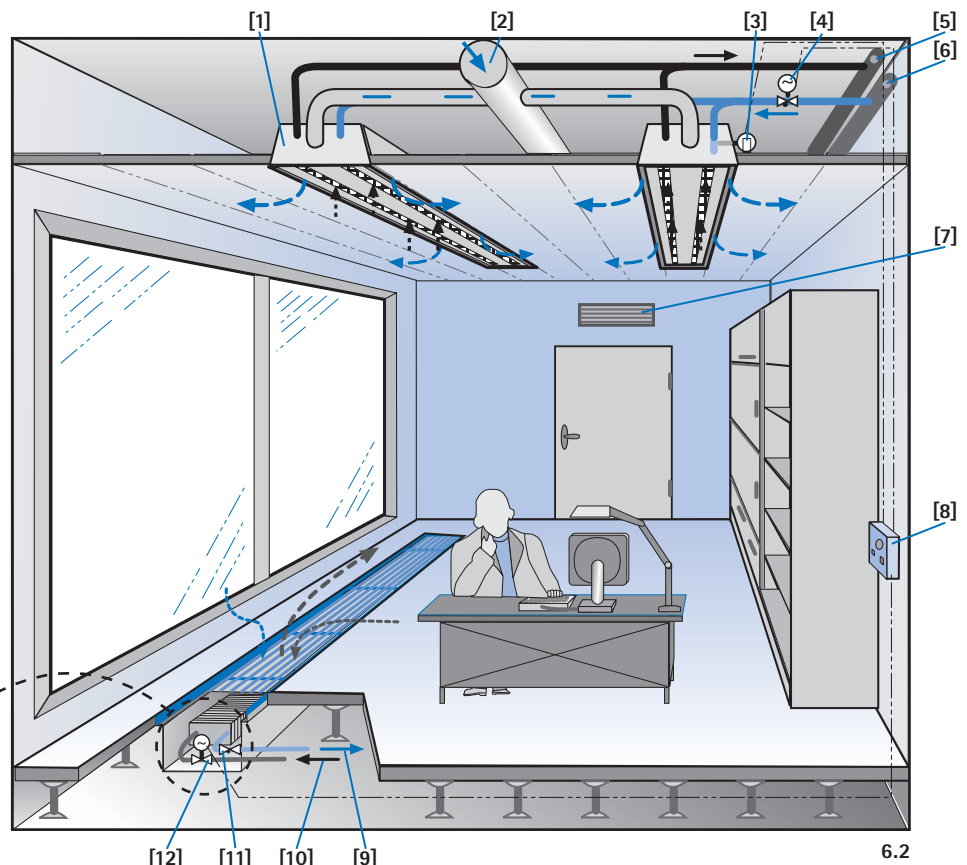
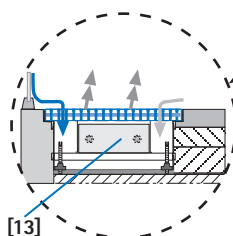

Gratings for Floor Units

Types | Features | Measurement

Grating types

TTC Floor Units are supplied with longitudinal gratings made of natural coloured, anodised aluminium profiles as standard, see Fig. 7.1–7.21. Alternatively, flexible cross gratings are also available, see Fig. 7.3, lieferbar.

Cross gratings made of untreated special steel hollow profiles (V2A) can also be supplied for specific applications.

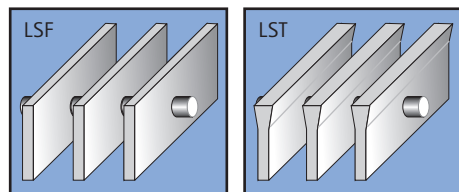

7.1 Longitudinal grating made of flat profile aluminium

7.12 Longitudinal grating made of T-profile aluminium

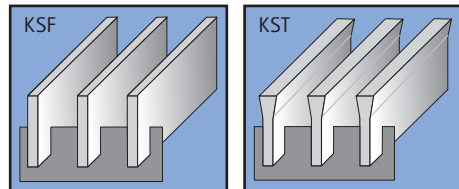

7.2 Comb grating made of flat profile aluminium

7.21 Comb grating made of T-profile aluminium

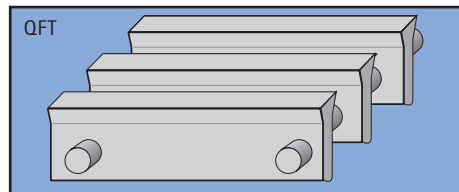

7.3 Cross grating (flexible) made of T-profile aluminium

90° mitred corners

Longitudinal grating, 90° mitred corner (available in rigid or flexible design)

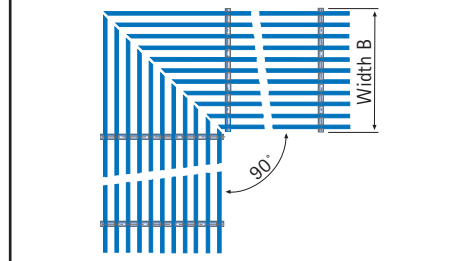

7.4

Comb grating, 90° mitred corner (available in rigid or flexible design)

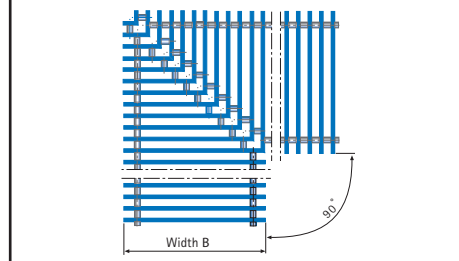

7.5

Mitred ends

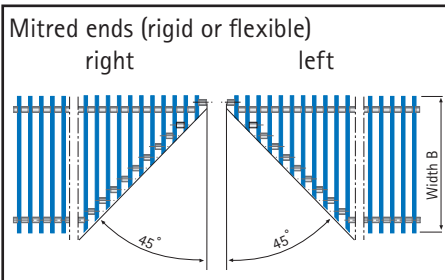

7.6

Curved segment

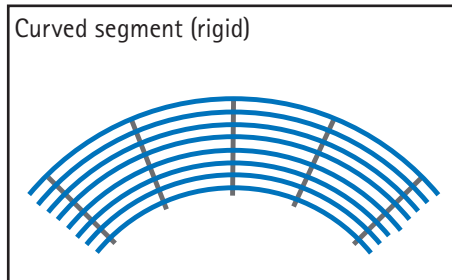

7.8

Notches for columns or façade pillars

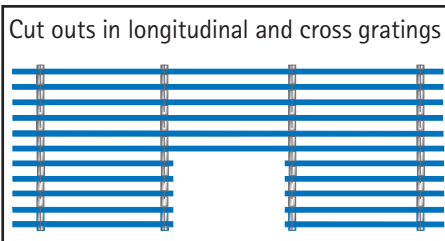

7.7

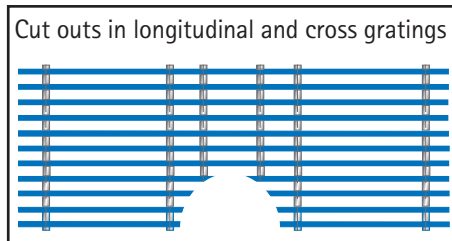

7.9

Examples how to take measurements for special designs

TTC Floor Units can be ordered to match any architectural requirement by selecting the appropriate mitred corners and cuts. However, this requires exact measurements to be taken on site. **It is very important to state what has been measured, the dimensions of the outer frame or the dimensions of the clear inner frame.**

Example 1

These measurements are required for banded layouts with mitre angles from 90° to 179°.

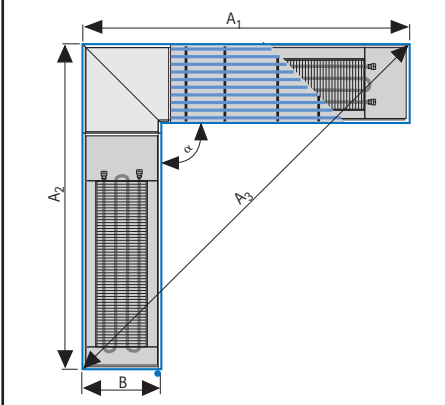

7.10

Example 2

These measurements are required for banded layouts with mitre angles from 90° to 179°.

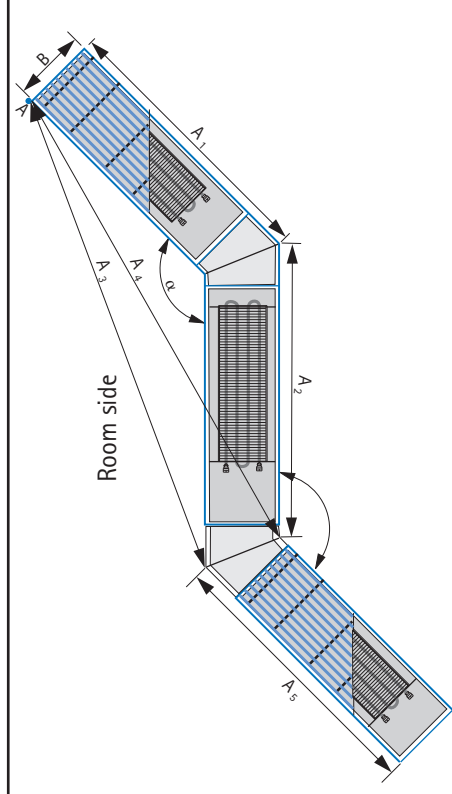

7.11

Example 3

Curved segment

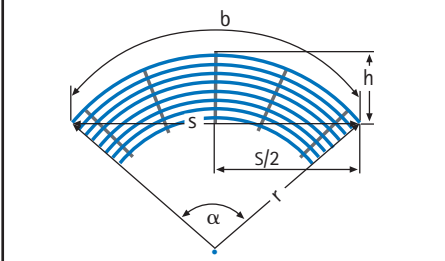

7.12

FHOK 2.17/2.24

Convective heating mode

Features of the FHOK2 series

Floor Units of the FHOK2. series have been designed for installation in precast floors. They are ideal for protecting a room against cold air radiation in front of large glassed areas and they prevent cold air from penetrating the room. In addition, the whole of the room can be heated using TTC Floor Units. The design of the units is described below.

Heat exchanger

- Heat exchanger made of copper pipes with aluminium fins (coated black)
- Fixed mechanical joint between the fins and the pipes (high heating capacity)
- The water quality of the heating medium must comply with the German engineering standard, VDI Directive 2035
- Finned convector length L_{ripped} , (Fig. 8.4)
- Maximum operating pressure 6 bar (other operating pressures are possible)
- Maximum operating temperature 90°C

Connections

- Standard connection side is on the right viewed from the room. Punched openings allow the connections to be installed alongside or on the face.
- Brass fittings Rp 1/2" (female thread)
- Air bleed valve as standard

Floor trench

- Floor trench made of anodised steel plate and coated black. For dimensions see Fig. 8.2–8.3.1
- The top edge of the floor trench is finished with a profile edge matching the colour and the material of the grating
- A height adjustment device which can be set from the top is located on the inside of the floor trench
- The floor trench can be secured to the floor using fixing plates

Gratings

With natural anodised aluminium longitudinal gratings as standard. Other grid designs, materials and colours on request.

Optional extras

Protection cover, exterior insulation

Applications

Office and administrative buildings, exhibition spaces, restaurants, show rooms, conservatories, luxury domestic spaces

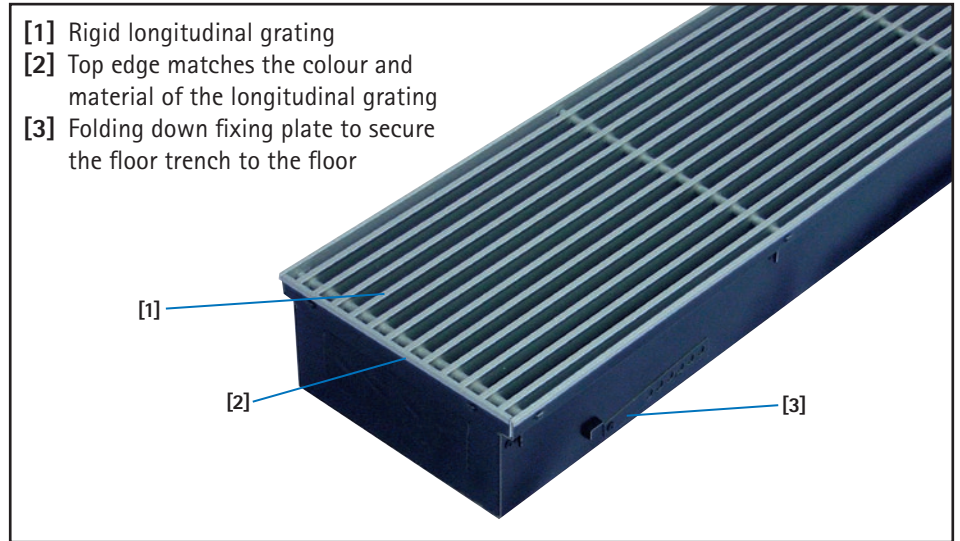

8.1

Technical data

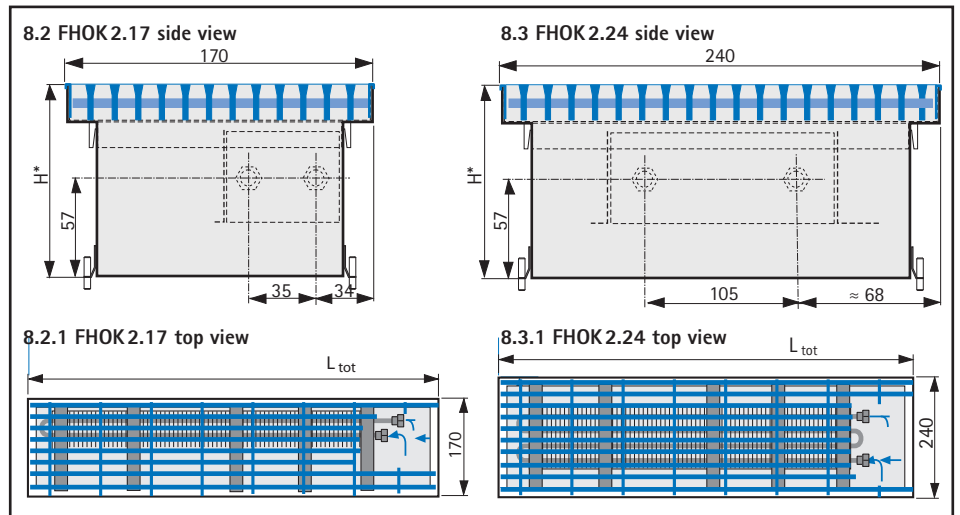

8.2–8.3.1

General tolerances compliant with the German standard DIN 7168/Part 1 (rough)

Technical data | Weights | Water content

Length L_{tot} [mm]	Finned length [mm]	FHOK 2.17			FHOK 2.24		
		Depth D [mm]	Water content [l]	Weight [kg]	Depth D [mm]	Water content [l]	Weight [kg]
900	600	170	0,8	8	240	1,10	10
1200	900	170	1,2	12	240	1,65	15
1500	1200	170	1,6	16	240	2,20	20
1800	1500	170	2,0	20	240	2,75	25
2100	1800	170	2,4	24	240	3,30	30
2400	2100	170	2,8	28	240	3,85	35

8.4

Note:

Height »H«, will vary depending on the type of grate used, see Table 4.1 on page 4. Please refer to the Order Key on page 4.

FHOK 2.17/2.24

Heating capacity | Water-sided pressure difference

Heating capacity for FHOK 2.17

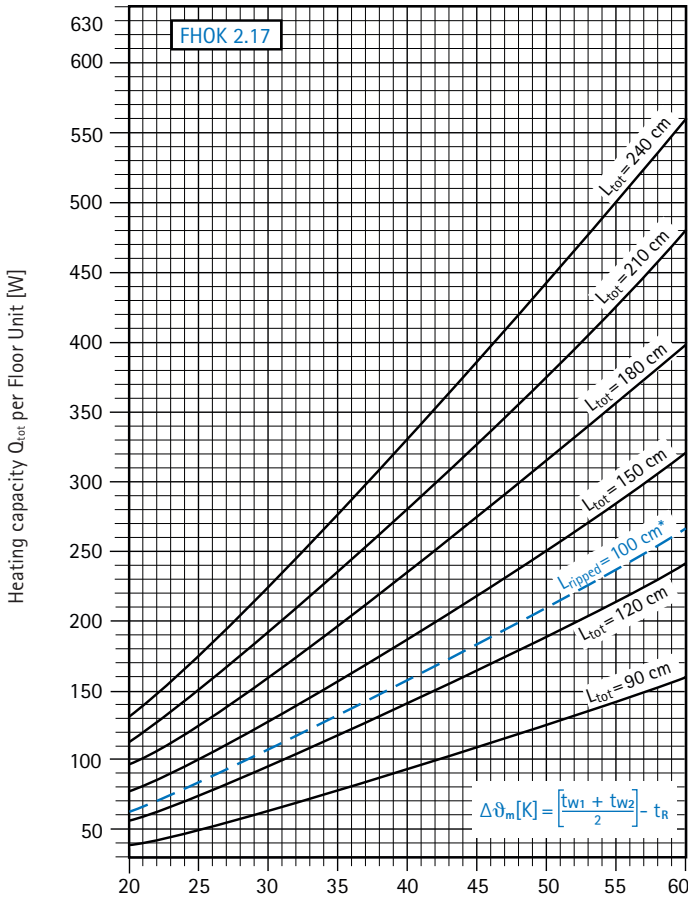

9.1 Mean Temperature difference $\Delta\theta_m$ [K] *specif. heating capacity \dot{q}_{spec} [W/m]

Heating capacity for FHOK 2.24

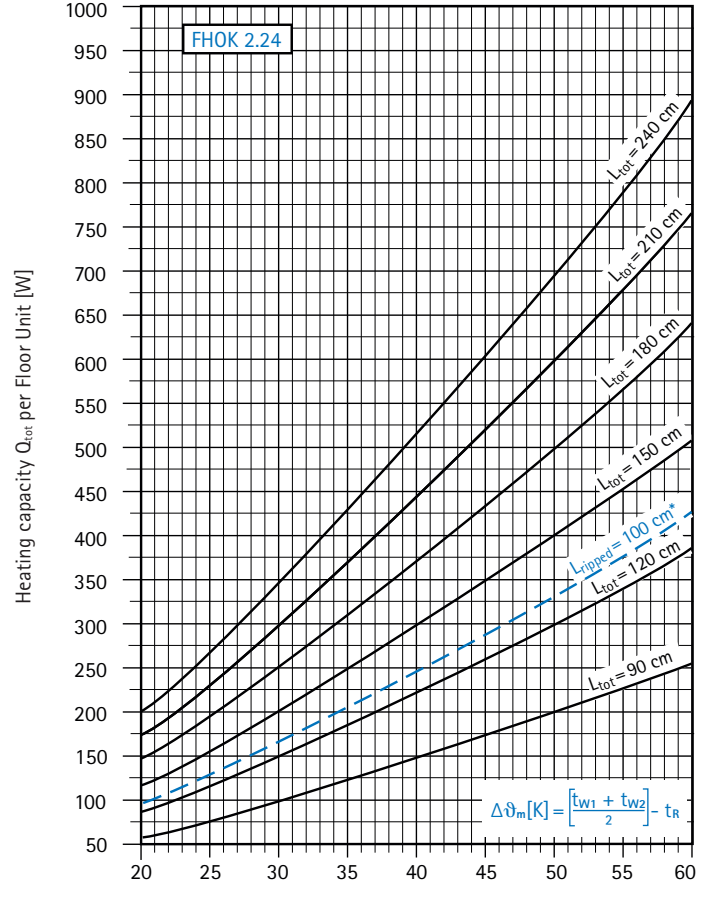

9.3 Mean Temperature difference $\Delta\theta_m$ [K] *specif. heating capacity \dot{q}_{spec} [W/m]

Water-sided pressure difference for FHOK 2.17

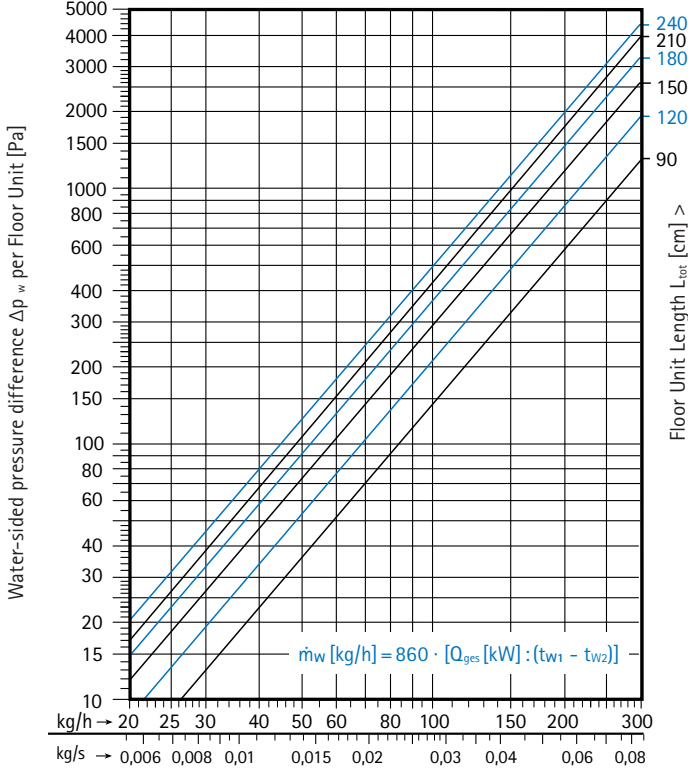

9.2 Water volume flow m_w

Water-sided pressure difference for FHOK 2.24

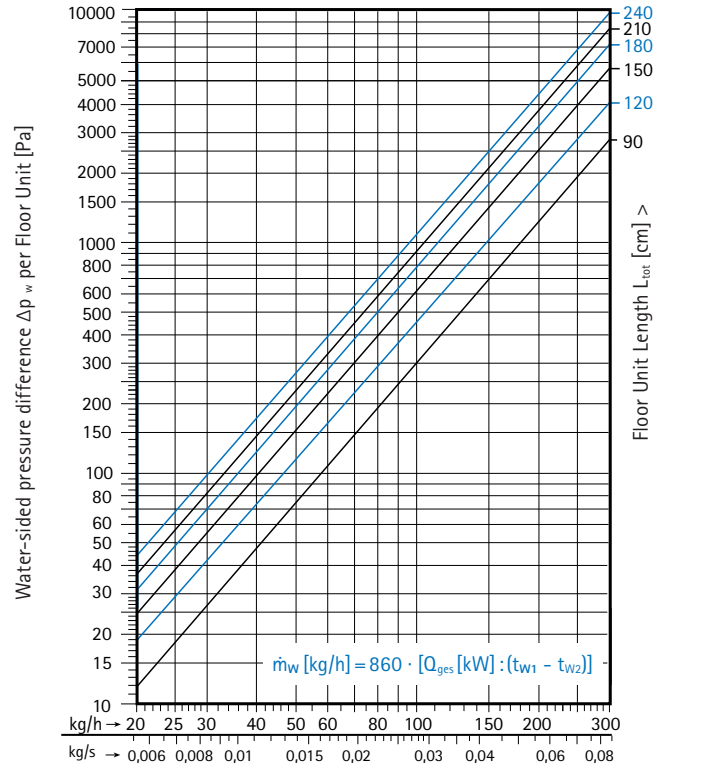

9.4 Water volume flow m_w

t_{w1} = Water inlet [°C]; t_{w2} = Water discharge [°C]; t_r = Room temperature

Subject to technical changes · Issued 10/2010

Features of the FHKI series

FHKI Floor Units have been designed for heating and cooling mode and operate following the induction principle. Outside air, which has been pre-conditioned in a central ventilation system, passes through a special pressure chamber system and takes in room air via the heat exchanger. FHKI Floor Units are an excellent protection against cold air radiation in front of large glassed areas and prevent cold air from entering the room. They can be used to both heat and cool the whole of the room. Installation is level with the floor.

Heat exchanger

- Heat exchanger made of copper pipes with aluminium fins (coated black)
- Fixed mechanical joint between the fins and the pipes (high heating capacity)
- The water quality of the heating medium must comply with the German engineering standard, VDI Directive 2035
- Maximum operating pressure 6 bar
- Maximum operating temperature 90°C
- Available as a 2 pipe or a 4 pipe system

Connections

- Standard connection side is on the right viewed from the room. Punched openings allow the connections to be installed alongside or on the face.
- Brass fittings Rp 1/2" (female thread)
- Air bleed valve as standard

Floor trench

- Floor trench made of anodised steel plate and coated black, for dimensions see Fig. 10.2–10.3
- The top edge of the floor trench is finished with a profile edge matching the colour and the material of the grating
- A height adjustment device which can be set from the top is located on the inside of the floor trench
- The floor trench can be secured to the floor using fixing plates

Gratings

With natural anodised aluminium longitudinal gratings as standard. Other grid designs, materials and colours on request.

Optional extras

Protection cover, exterior insulation

Einsatzbereiche

Office and administrative buildings, exhibition spaces, restaurants, show rooms

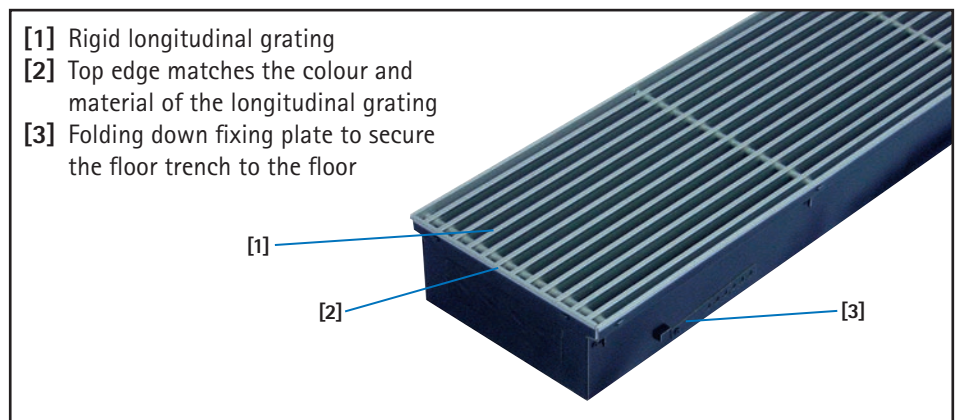

10.1

Technical data

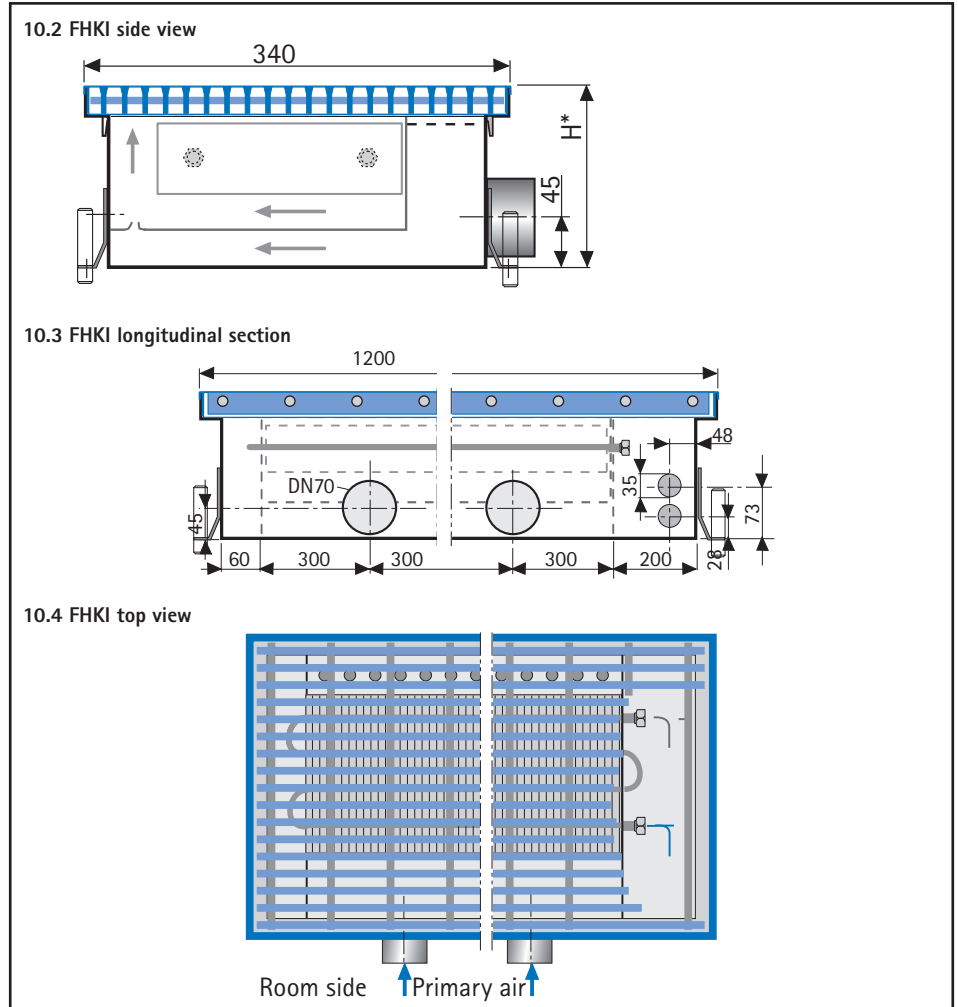

10.2–10.4

General tolerances compliant with the German standard DIN 7168/Part 1 (rough)

Technical data | Weights | Water content

Length L_{tot} [mm]	Finned length [mm]	FHKI	
		Water content [l]	Weight [kg]
1200	900	1,65	22

10.5

Note:

Height »H«, will vary depending on the type of grate used, see Table 4.1 on page 4. Please refer to the Order Key on page 4.

FHKI Power Level 1 | 2 pipe system

Level 1 cooling capacity

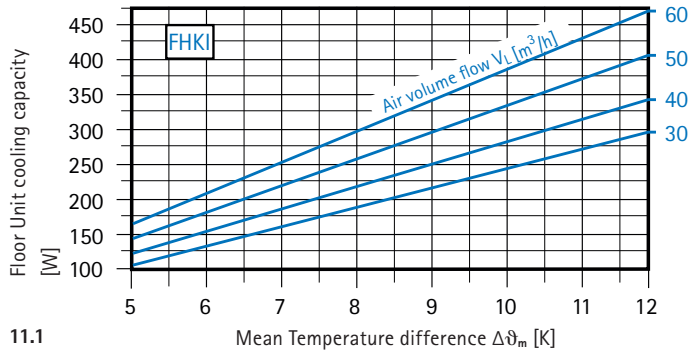

Level 1 heating capacity

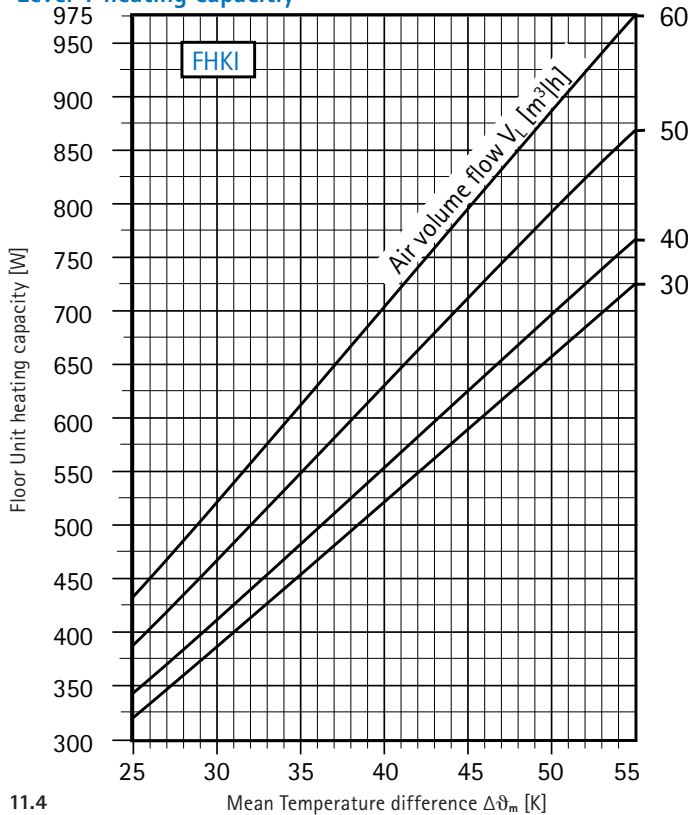

FHKI Power Level 2 | 2 pipe system

Level 2 cooling capacity

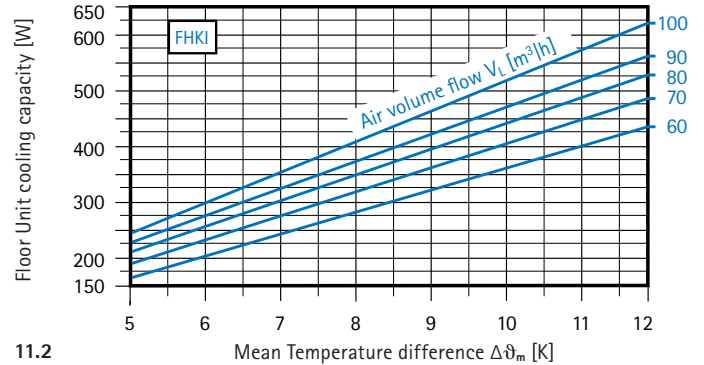

Level 2 heating capacity

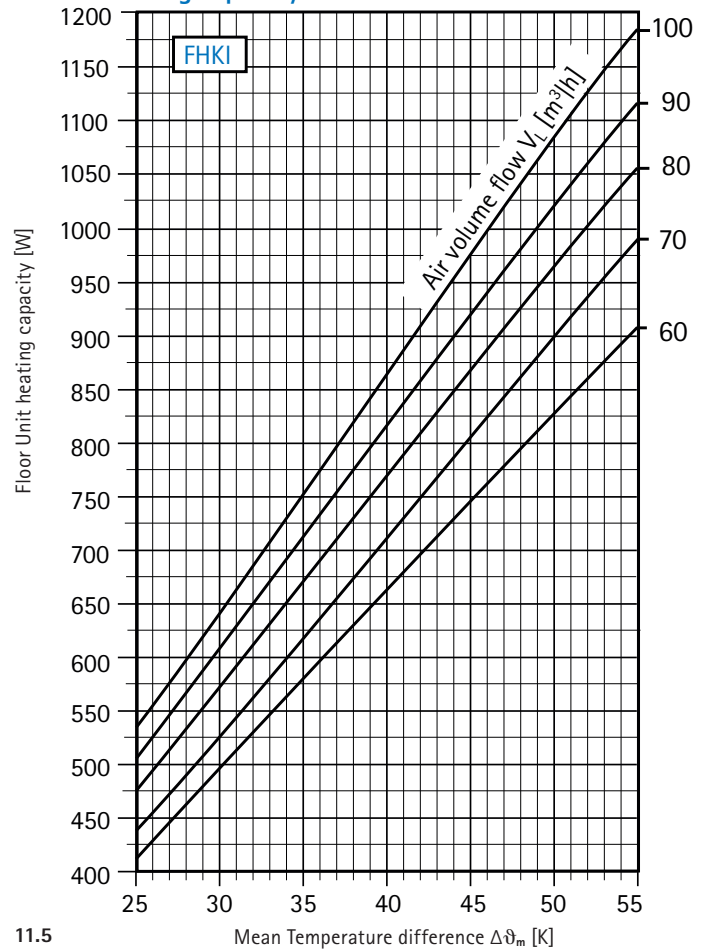

Water-sided pressure difference for FHKI

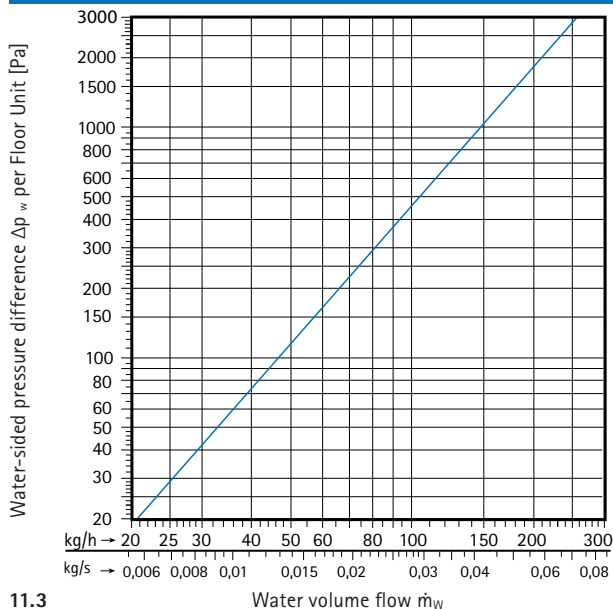

FHOQ

Heating using displacement air

Features of the FHOQ series

FHOQ Floor Units have been designed for heating mode. They operate following the convection and displacement air principles. Outside air, which has been pre-conditioned in a central ventilation system, is released into the room with a low air flow rate. In addition, room air will be heated using the heat exchanger. FHOQ Floor Units are an excellent protection against cold air radiation in front of large glassed areas and prevent cold air from entering the room. Installation is level with the floor.

Heat exchanger

- Heat exchanger made of copper pipes with aluminium fins (coated black)
- Fixed mechanical joint between the fins and the pipes (high heating capacity)
- The water quality of the heating medium must comply with the German engineering standard, VDI Directive 2035
- Maximum operating pressure 6 bar
- Maximum operating temperature 90°C

Connections

- Standard connection side is on the right viewed from the room. Punched openings allow the connections to be installed alongside or on the face.
- Brass fittings Rp 1/2" (female thread)
- Air bleed valve as standard

Floor trench

- Floor trench made of anodised steel plate and coated black, for dimensions see Fig. 12.2–12.6
- The top edge of the floor trench is finished with a profile edge matching the colour and the material of the grating
- A height adjustment device which can be set from the top is located on the inside of the floor trench
- The floor trench can be secured to the floor using fixing plates

Gratings

With natural anodised aluminium longitudinal gratings as standard. Other grid designs, materials and colours on request.

Optional extras

Protection cover, exterior insulation

Applications

Offices and exhibition spaces, restaurants, administrative buildings

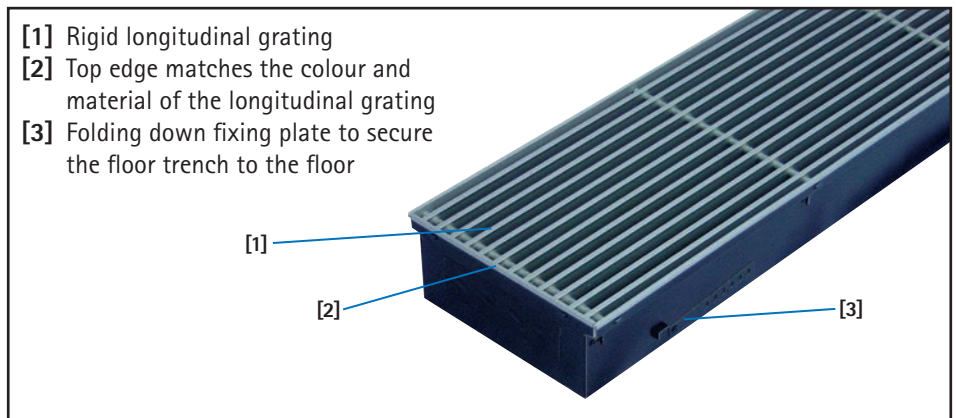

12.1

Technical data

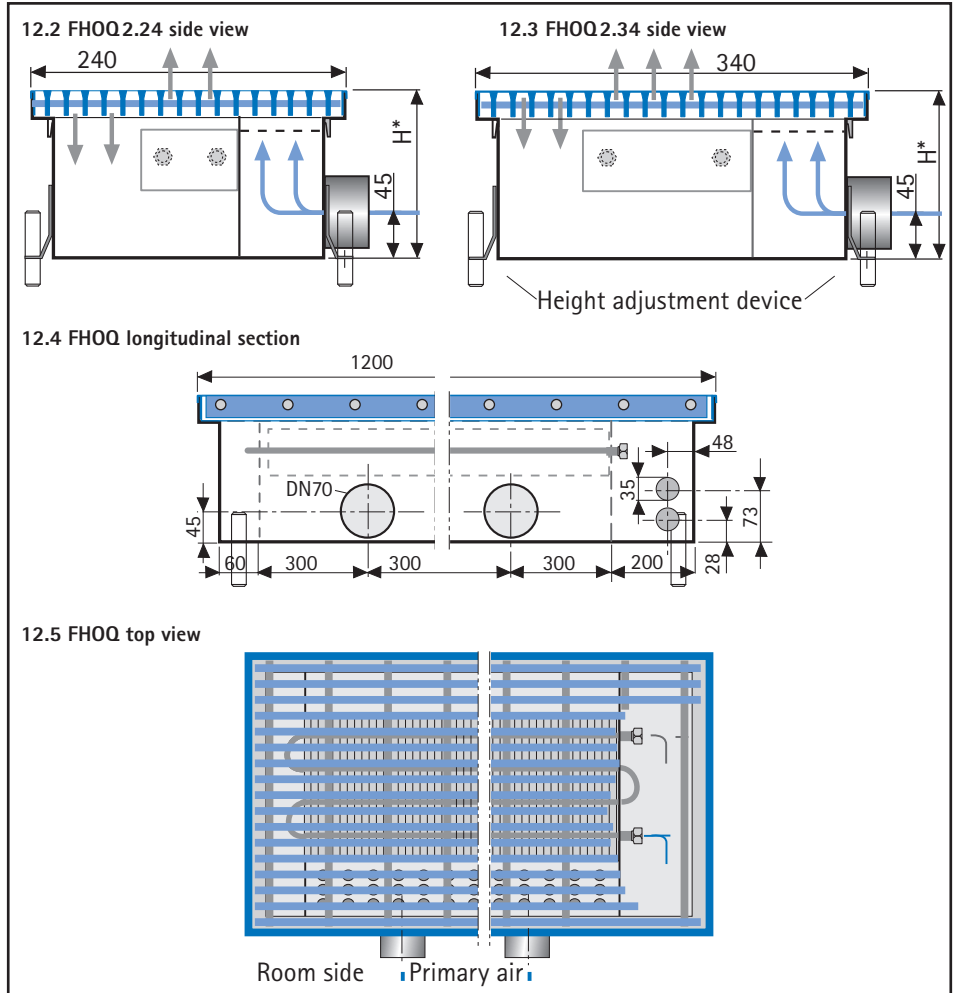

12.2–12.5

General tolerances compliant with the German standard DIN 7168/Part 1 (rough)

Technical data | Weights | Water content

Length L_{tot} [mm]	Finned length [mm]	FHOQ Depth [mm]	Water content [l]	Weight [kg]
1200	900	240	1,65	15
1200	900	340	2,5	20

12.6

Note:

Height »H«, will vary depending on the type of grate used, see Table 4.1 on page 4. Please refer to the Order Key on page 4.

FHOQ 2.24/2.34

Heating capacity | Water-sided pressure difference

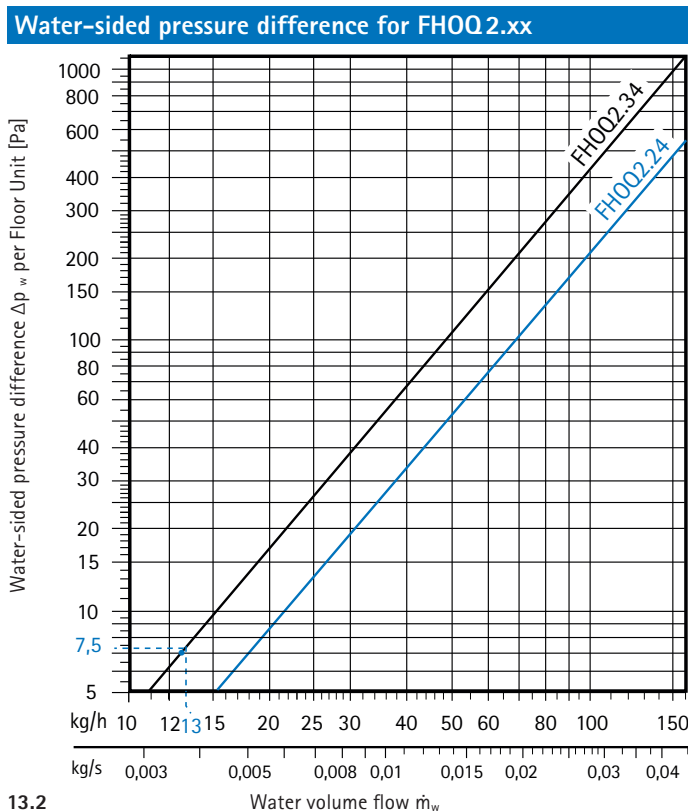
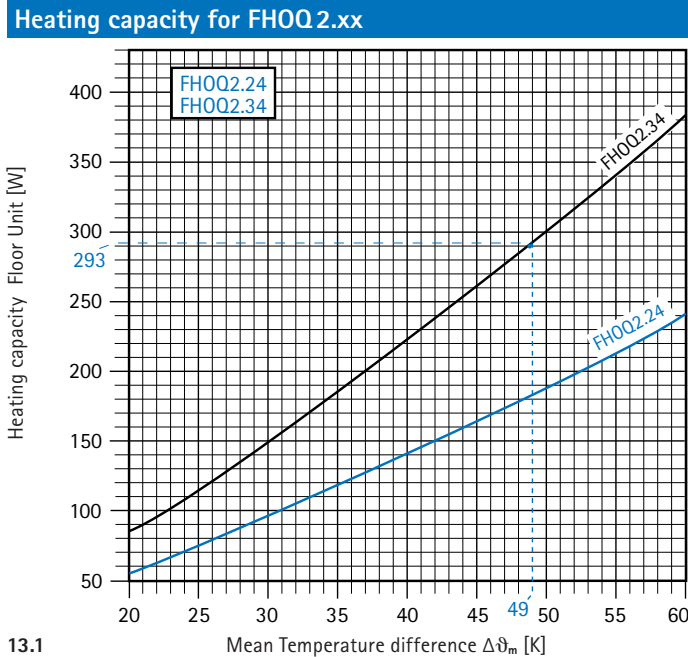

Formula 1.1 to calculate the mean temperature $\Delta\vartheta_m$ between two different media, for heating mode

$$\Delta\vartheta_m[\text{K}] = \frac{t_{w1}[\text{°C}] + t_{w2}[\text{°C}]}{2} - t_R$$

Formula 2 to roughly estimate the water volume flow \dot{m}_w

$$\dot{m}_w[\text{kg/h}] = 860 \cdot \frac{Q_{\text{HW}}[\text{kW}]}{(t_{w1} - t_{w2})}$$

Heating capacity of the supply air

Supply air volume flow $\dot{V}_{\text{ASA}}[\text{m}^3/\text{h}]$	Difference between room and supply air temperature Δt_L in degrees Kelvin [K]							
	2	6	8	10	12	14	16	
40	26,7	53,3	80	107	133	160	187	213
80	53,3	107	160	213	267	320	373	427
120	80	160	240	320	400	480	560	640
160	107	213	320	427	533	640	747	853
200	133	267	400	533	667	800	933	1067
240	160	320	480	640	800	960	1120	1280
280	187	373	560	747	933	1120	1307	1493
240	200	400	600	800	1000	1200	1400	1600

13.1

Heating capacity of the supply air
How to calculate the heating capacity of an FHOQ 2.34 Floor Unit given the conditions below

- Warm water inlet $t_{w1} = 80^\circ\text{C}$
- Warm water discharge $t_{w2} = 60^\circ\text{C}$
- Room temperature $t_R = 21^\circ\text{C}$
- Supply air flow $\dot{V}_{\text{LZU}} = 120 \text{ m}^3/\text{h}$
- Supply air temperature $t_{\text{LZU}} = 29^\circ\text{C}$

Calculation:

1. Firstly, you will need to calculate the water-sided heating capacity Q_{HW} using the figures in Table 13.1 and formula 1.1

$$\Delta\vartheta_m[\text{K}] = \frac{80^\circ\text{C} + 60^\circ\text{C}}{2} - 21^\circ\text{C} = 70^\circ\text{C} - 21^\circ\text{C} = 49 \text{ K}$$

For $\Delta\vartheta_m = 49 \text{ K}$ Table 13.1 will give a water-sided heating capacity of \dot{Q}_{HW} für FHOQ 2.34 = 293 W

2. To calculate the water-sided pressure difference Δp_w you will need to calculate the water volume flow \dot{m}_w using formula 2

$$\dot{m}_w[\text{kg/h}] = 860 \cdot \frac{0.293 \text{ [kW]}}{(80^\circ\text{C} - 60^\circ\text{C})} = 860 \cdot 0,015 = 12,9 \text{ kg/h}$$

For the water volume flow $\dot{m}_w = 13 \text{ kg/h}$ Table 13.2 will give a water-sided pressure difference of $\Delta p_w \approx 7,5 \text{ Pa}$

3. Additional heating capacity of the supply air (displacement air):

- Supply air volume flow $V_{\text{LZU}} = 120 \text{ m}^3/\text{h}$
- Supply air temperature $t_{\text{LZU}} = 29^\circ\text{C}$
- Room air temperature $t_R = 21^\circ\text{C}$
- Temperature difference $\Delta t = t_{\text{LZU}} - t_R = 8 \text{ K}$

For 8 K and 120 m^3/h Table 13.3 will give a heating capacity of $Q_{\text{LZU}} = 320 \text{ W}$

Result:

$$Q_{\text{Hges}} = Q_{\text{HW}} + Q_{\text{LZU}} = 293 \text{ W} + 320 \text{ W} = 613 \text{ W}$$

FOOQ

Distribution channel for displacement air

Features of the FOOQ series

FOOQ Floor Units have been designed for heating, ventilating or cooling, depending on the state of the displacement air. Outside air which has been pre-conditioned in a central ventilation system, passes through a special distribution chamber from where it is released into the room as displacement air with a low air flow rate. The room air which sinks down in front of cold glassed areas and outside walls mixes with the displacement air released into the room and will either heat or cool the room. Installation of the Floor Units is level with the floor.

Floor trench

- Floor trench made of anodised steel plate and coated black, for dimensions see Fig. 14.2-14.5
- The top edge of the floor trench is finished with a profile edge matching the colour and the material of the grating
- A height adjustment device which can be set from the top is located on the inside of the floor trench
- To secure the floor trench to the floor the unit comes equipped with fixing plates on the sides which can be folded down

Air connections

- To connect the primary air supply 2 connecting pieces DN 70 are supplied as standard, see Fig. 14.2-14.5

Gratings

Units come with anodised, natural coloured aluminium longitudinal gratings as standard. Other grid designs, materials and colours on request.

Optional extras

Protection cover

Applications

Office and administrative buildings, exhibition spaces, restaurants

Note:

Height »H«, will vary depending on the type of grate used, see Table 4.1 on page 4. Please refer to the Order Key on page 4.. For rough capacity figures see Table 13.1 on page 13.

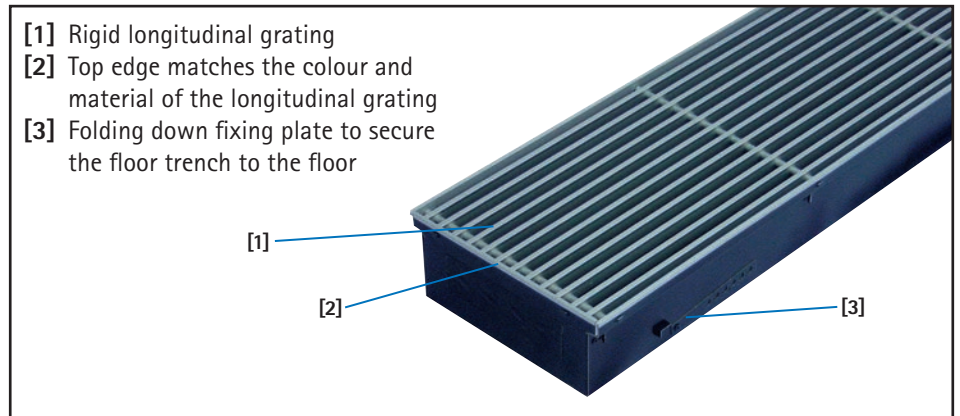

14.1

Technical data

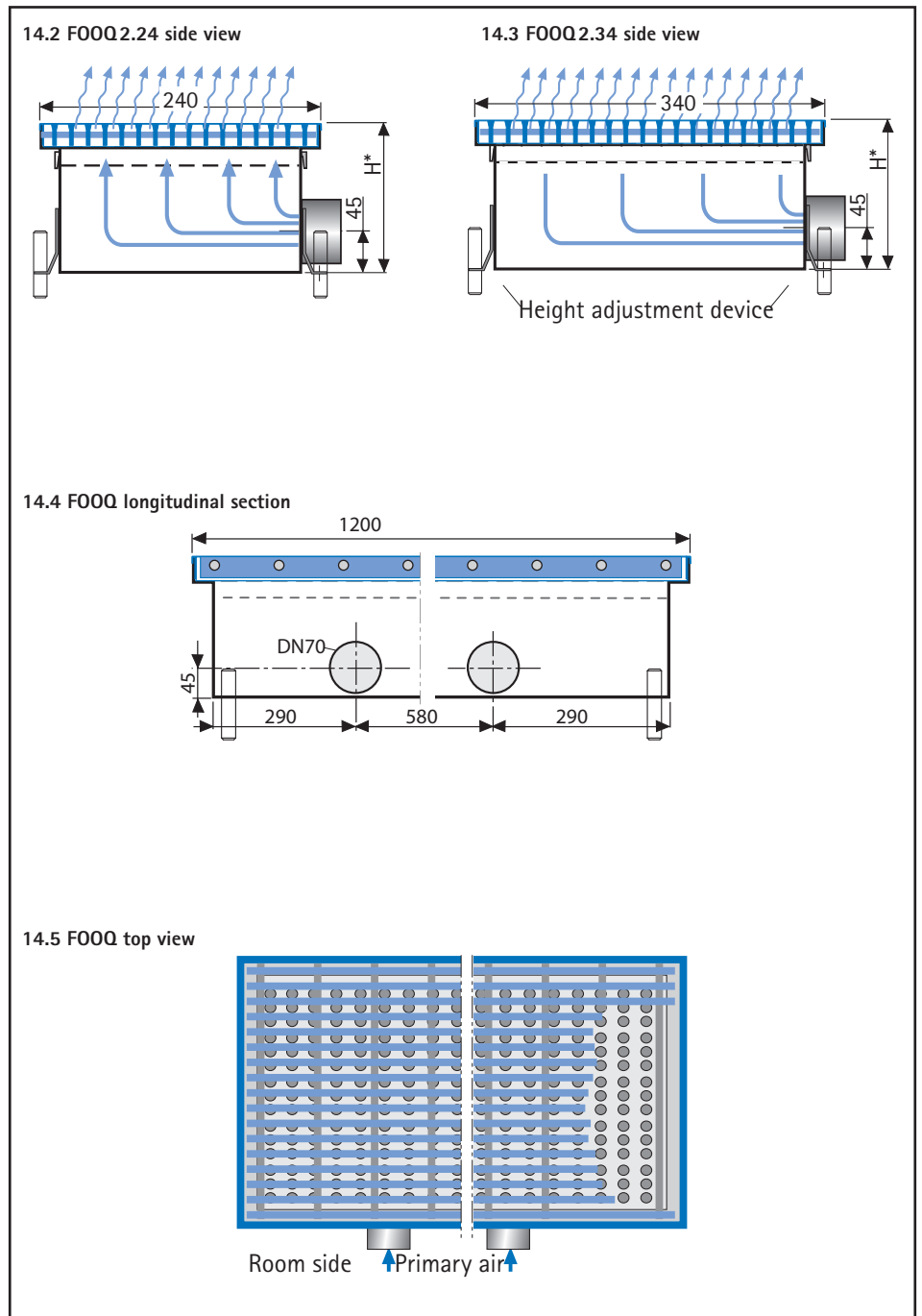

FHKV 4

Ventilation system supported heating and cooling



Features of the FHKV series

FHKV Floor Units have been designed for installation in floors. They can be used to heat or cool a room. In the winter the room is efficiently insulated from cold air in front of large glassed areas which can thus not penetrate the room. In the summer the cooled air rises along the façade and is dispersed into the room from the ceiling. Supplying recirculation air next to the façade results in an even temperature distribution in the room.

Heat exchanger:

- Heat exchanger made of copper pipes with aluminium fins (coated black)
- Fixed mechanical joint between the fins and the pipes
- Available as a 2 pipe or a 4 pipe system
- The water quality of the heating medium must comply with the German engineering standard, VDI Directive 2035
- Maximum operating pressure 10 bar
- Maximum operating temperature 90°C, other pressures and temperatures are possible

Connections:

- Standard connection side is on the left viewed from the room. Room sided openings allow the media pipe connections to be made through the trench wall.
- swivel nut connections with European cone seat 3/4"

Fan:

- Cross flow fans with energy saving EC motors, IP44 for high air flows and low noise levels
- Infinitely variable control via active 0–10V signal or potentiometer
- The maximum number of units that can be connected in a group depends on the total number of fans in the group. A maximum number of 10 fans in a group can be protected with a 16A (slow-blow) fuse.

Floor trench:

- Floor trench made of 1 mm anodised steel plate and coated black, for dimensions see Fig. 15.2–15.4
- Optional condensate tray
- Individual floor trenches. The top edge is finished with a profile edge matching the colour and the material of the grating
- A height adjustment device which can be set from the top is located at regular intervals below the grating support on the outside of the floor trench

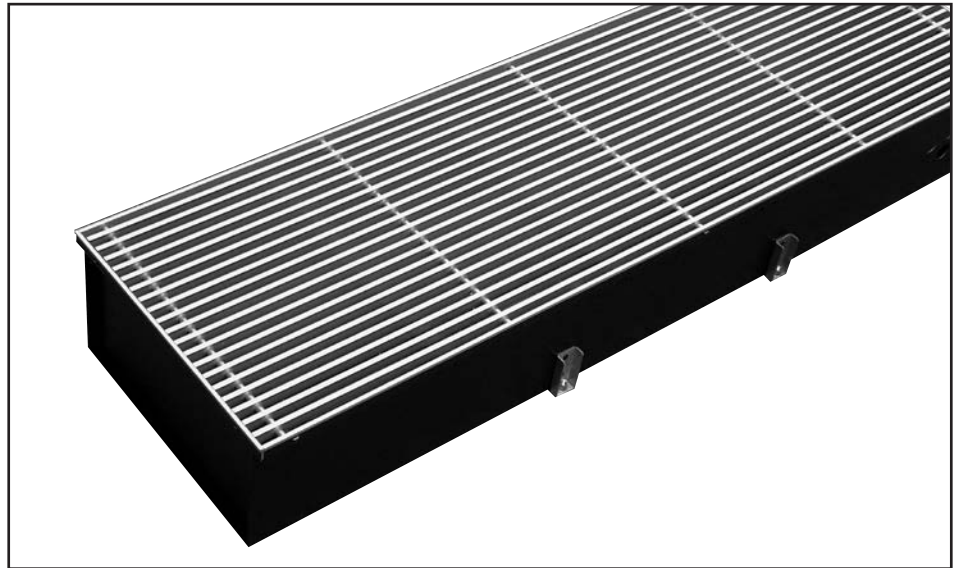

15.1 Unit shown with standard grating type LST 18.06.65 AN

Technical data

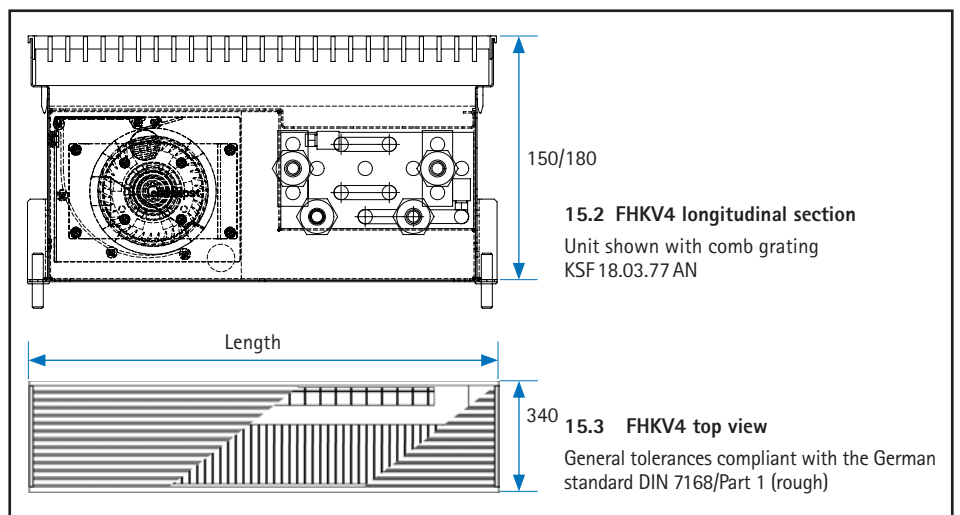

15.2–15.3

Dimensions

Depth [mm]	Height [mm]	Length (no. of fans) [mm]
340	150 (180 with comb grating)	1250 (1) – 1750 (1) – 2250 (2) – 2750 (2)

15.4

- To secure the floor trench to the unfinished floor the unit comes equipped with footfall sound insulated fixing plates

Gratings:

Units come with rigid, natural colour anodised, aluminium longitudinal gratings made of aerodynamically efficient aluminium T-profiles, 18 x 6 mm, as standard Bar spacing ~ 12 mm, ~ 65 % free cross section

Applications:

Office and administrative buildings, exhibition spaces, show rooms, restaurants

Optional extras:

Circulating air filter, room thermostat, speed controller (potentiometer), valve base, electrothermic actuator, lockshield valve, condensate tray insulation, outer insulation, protection cover, to be used during installation, centre cover with sound insulation

Length 1250 ▼

Cooling capacity FHKV (2 pipe and 4 pipe) L = 1250

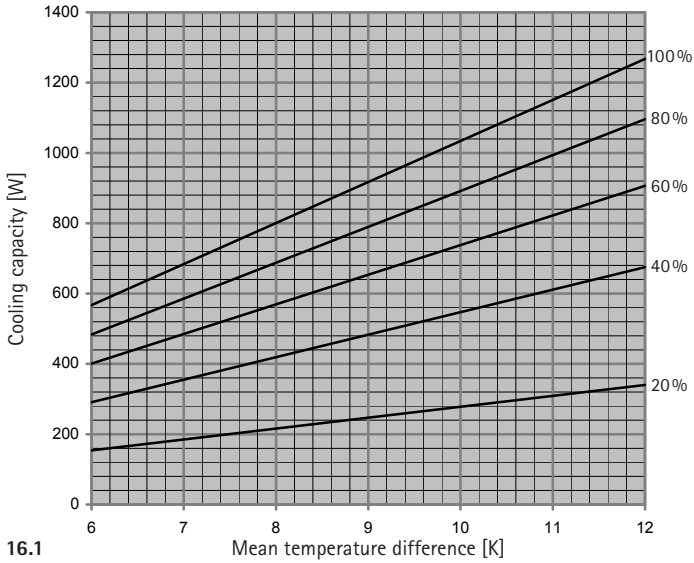

16.1

Length 1750 ▼

Cooling capacity FHKV (2 pipe and 4 pipe) L = 1750

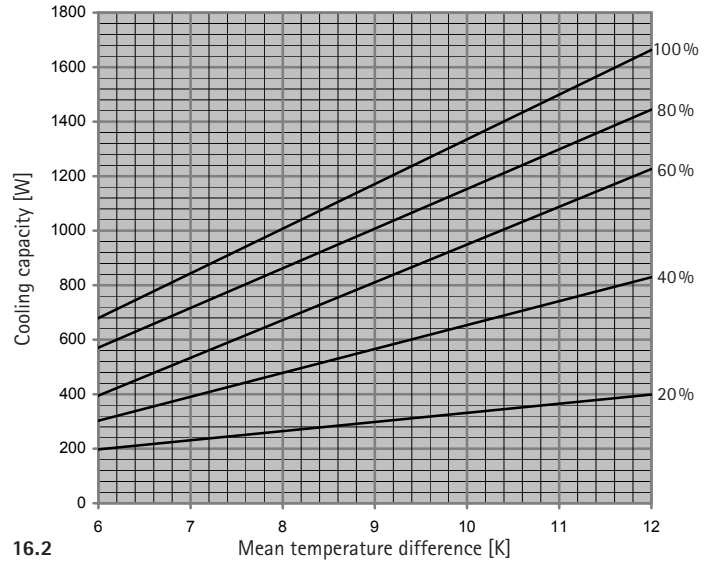

16.2

Heating capacity FHKV (2 pipe) L = 1250

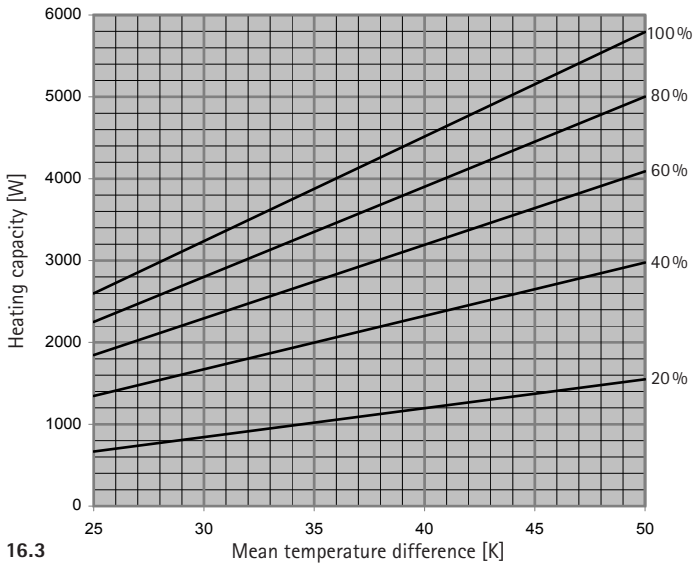

16.3

Heating capacity FHKV (2 pipe) L = 1750

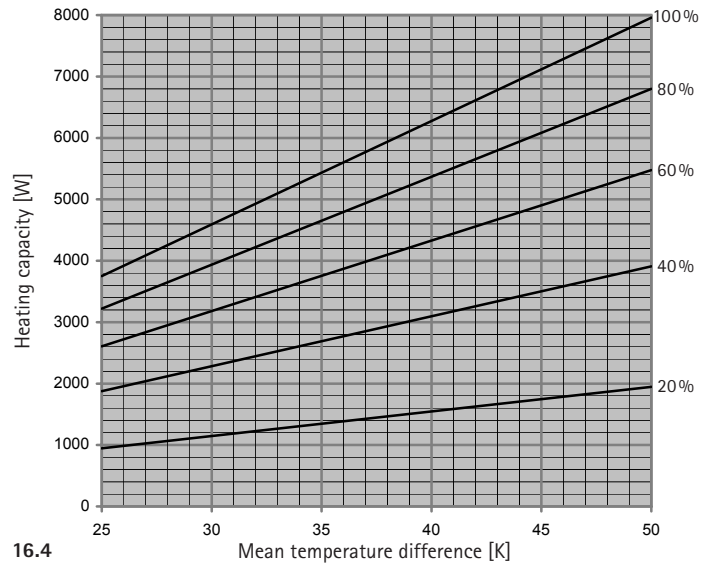

16.4

Heating capacity FHKV (4 pipe) L = 1250

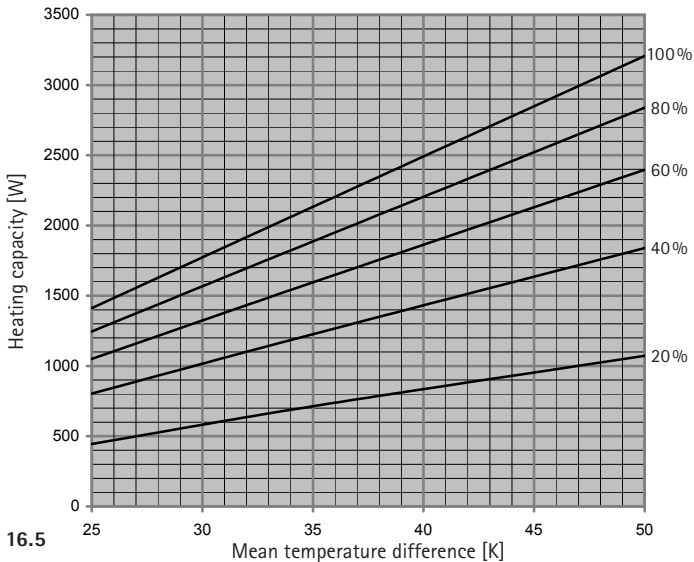

16.5

Heating capacity FHKV (4 pipe) L = 1750

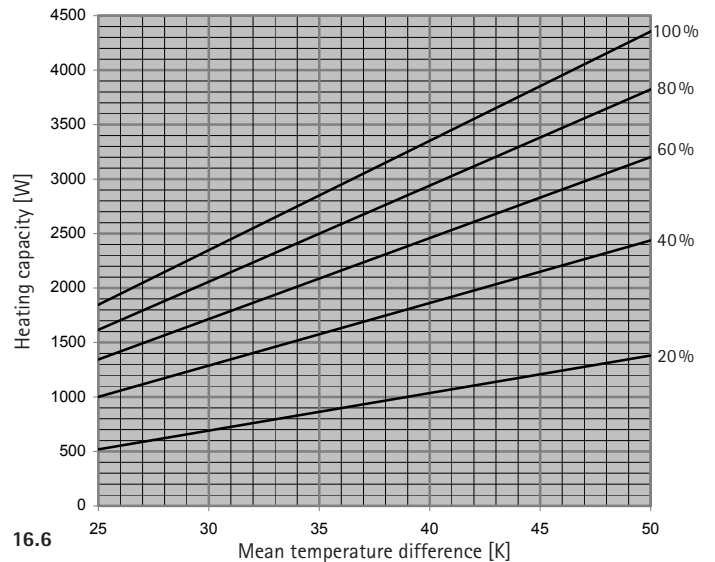

16.6

All heating capacity data is valid for a water-sided temperature spread of 10K.
 All cooling capacity data is sensitive cooling capacity when operated above dew point.

Length 2250 ▼

Cooling capacity FHKV (2 pipe and 4 pipe) L=2250

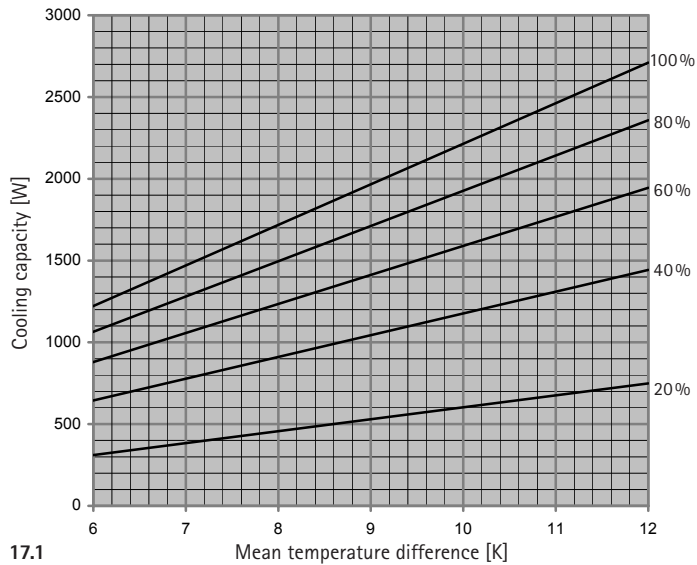

17.1

Length 2750 ▼

Cooling capacity FHKV (2 pipe and 4 pipe) L=2750

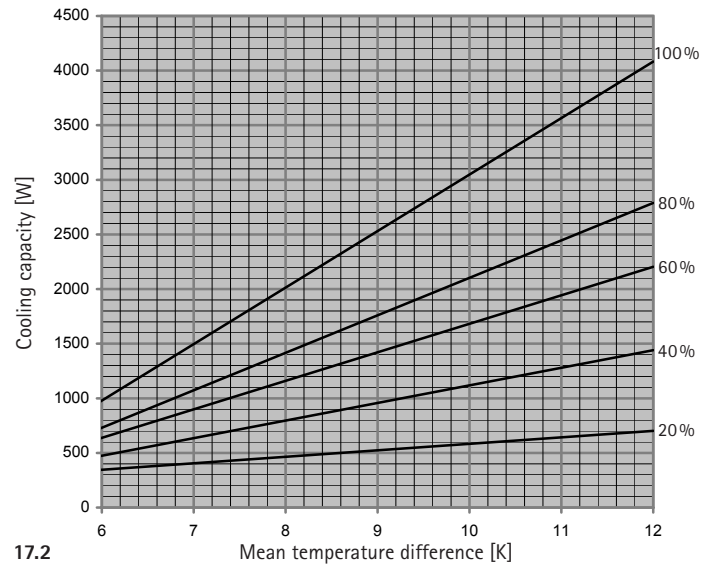

17.2

Heating capacity FHKV (2 pipe) L=2250

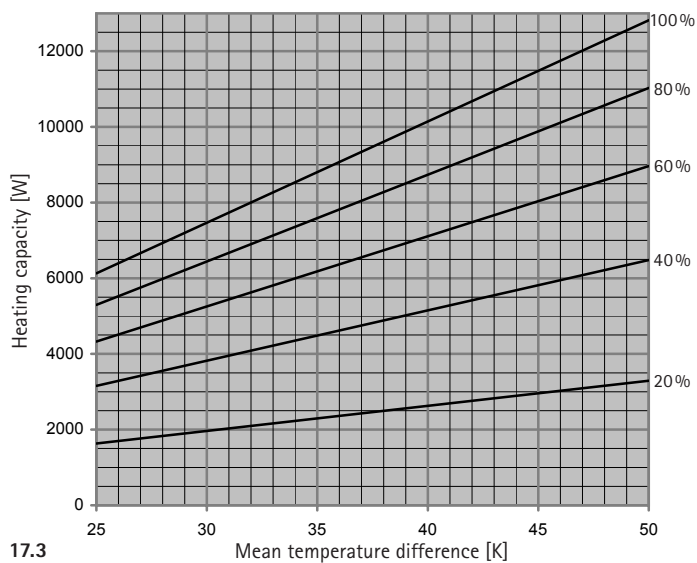

17.3

Heating capacity FHKV (2 pipe) L=2750

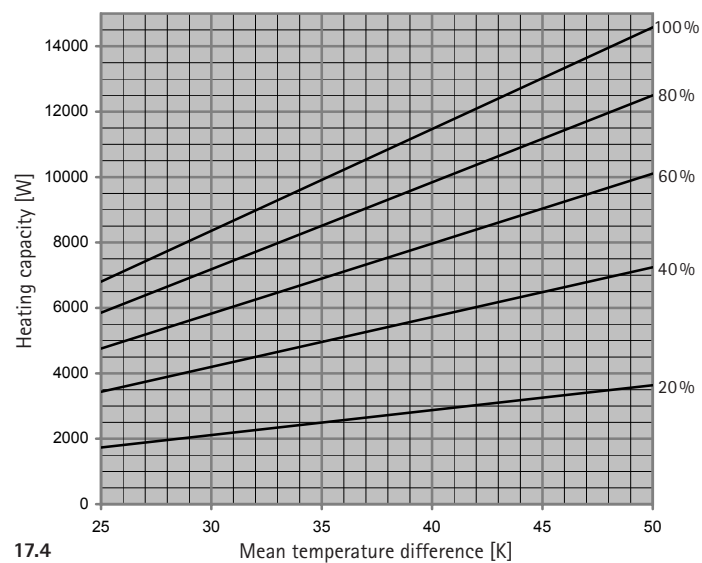

17.4

Heating capacity FHKV (4 pipe) L=2250

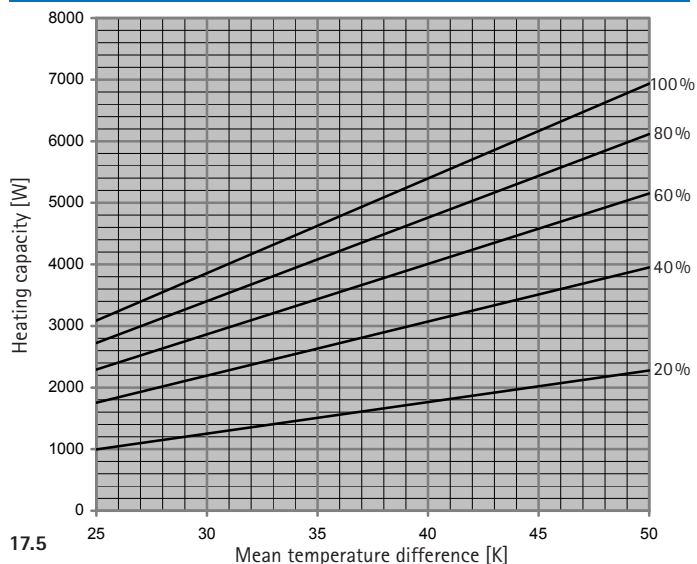

17.5

Heating capacity FHKV (4 pipe) L=2750

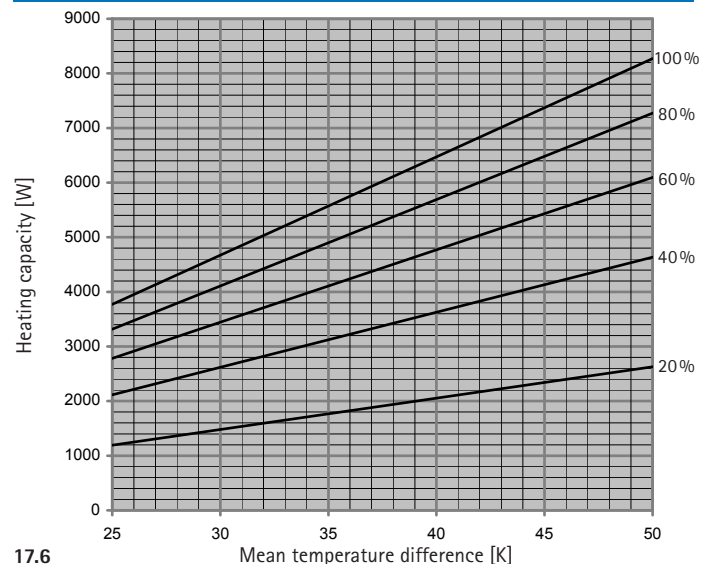

17.6

All heating capacity data is valid for a water-sided temperature spread of 10K.
All cooling capacity data is sensitive cooling capacity when operated above dew point.

Cooling pressure drops FHKV 4/2

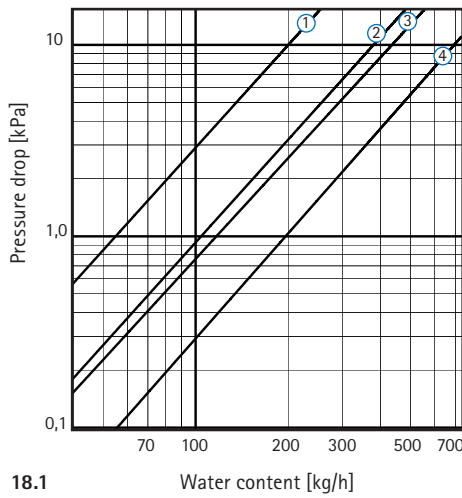

18.1 Water content [kg/h]

Heating pressure drops FHKV 4

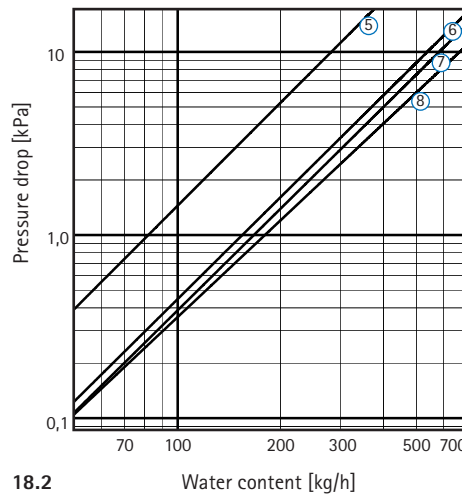

18.2 Water content [kg/h]

Heating pressure drops FHKV 2

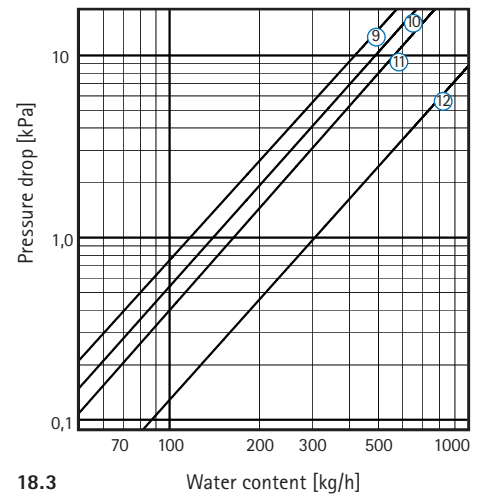

18.3 Water content [kg/h]

Allocation of pressure drop graphs, water flows according to German Engineering Standard (VDI) Directive 2035

TTC type	Length 1250 mm	Length 1750 mm	Length 2250 mm	Length 2750 mm
Cooling FHKV 2 u. 4 (2 & 4 pipe)	1	3	2	4
Heating FHKV 4 (4 pipe)	5	8	7	6
Heating FHKV 2 (2 pipe)	11	10	9	12

18.4

Calculating the heating and cooling capacity, and the water-sided pressure drop of an FHKV

How to calculate the capacity of an FHKV

- How to determine the unit length and type that can be installed
 Example: Façade grid measurement = 1350 mm
 => a 1250 mm long unit can be installed
 => possible types = FHKV4.34.125 or FHKV2.34.125

- How to calculate the cooling capacity of an FHKV:
 E.g.: $T_{\text{Inlet}}(t_{W1}) | T_{\text{Reflux}}(t_{W2}) | T_{\text{Room}}(t_R) = 16 | 18 | 26^\circ\text{C}$

Use the following formula to calculate the mean temperature difference Δv_m for cooling:

$$\Delta v_m = t_R - (t_{W1} + t_{W2}) / 2$$

$$\Rightarrow \Delta v_m = 26^\circ\text{C} - (16^\circ\text{C} + 18^\circ\text{C}) / 2 = 9\text{K}$$

Fig. 16.1 illustrates the cooling capacity at 9 K using speeds from 20% to 100%.

We recommend calculating the cooling capacity for 40% speed.
 => $\dot{Q}_k = 442\text{W}$

- How to calculate the heating capacity of an FHKV:
 E.g.: $T_{\text{Inlet}}(t_{W1}) | T_{\text{Reflux}}(t_{W2}) | T_{\text{Room}}(t_R) = 60 | 50 | 22^\circ\text{C}$

Use the following formula to calculate the mean temperature difference Δv_m for heating:

$$\Delta v_m = (t_{W1} + t_{W2}) / 2 - t_R$$

$$\Rightarrow \Delta v_m = (60^\circ\text{C} + 50^\circ\text{C}) / 2 - 20 = 35\text{K}$$

Check if you have a 2 pipe or a 4 pipe system. If you have a 4 pipe system, Fig. 16.2 illustrates the heating capacity using speeds from 20% to 100%.

We recommend calculating the cooling capacity for 40% speed.
 => $\dot{Q}_h = 1220\text{W}$

Fig. 17.3 illustrates the heating capacity for the 2 pipe system.
 => $\dot{Q}_h = 2000\text{W}$

How to calculate the pressure drop of an FHKV

- How to calculate the water flow for cooling
 E.g.: $T_{\text{Inlet}}(t_{W1}) | T_{\text{Reflux}}(t_{W2}) | \text{Length} = 16 | 18^\circ\text{C} | 1250\text{mm}$

Use the following formula to calculate the water flow required for cooling:

$$\dot{m}_W = 860 \times \dot{Q}_k / (t_{W2} - t_{W1})$$

$$\Rightarrow \dot{m}_W = 860 \times 0,422\text{ kW} / (18^\circ\text{C} - 16^\circ\text{C}) = 190\text{ kg/h}$$

- How to determine the water-sided pressure drop for cooling:
 Use the allocation table 18.4 for pressure drop graphs, the unit length and type to determine the associated water-sided pressure drop graph.

=> Graph 1

Fig. 18.1 illustrates the water-sided pressure drop for a water flow of 190 kg/h. => $\Delta P = 9\text{ kPa}$

- How to calculate the water flow for heating (4 pipe system)
 E.g.: $T_{\text{Inlet}}(t_{W1}) | T_{\text{Reflux}}(t_{W2}) | \text{Length} = 60 | 50^\circ\text{C} | 1250\text{mm}$

Use the following formula to calculate the mean water flow required for heating:

$$\dot{m}_W = 860 \times \dot{Q}_k / (t_{W2} - t_{W1})$$

$$\Rightarrow \dot{m}_W = 860 \times 1,22\text{ kW} / (60^\circ\text{C} - 50^\circ\text{C}) = 105\text{ kg/h}$$

- How to determine the water-sided pressure drop for heating:
 Use the allocation table 18.4 for pressure drop graphs, the unit length and type to determine the associated water-sided pressure drop graph.

=> Graph 5

Fig. 18.2 illustrates the water-sided pressure drop for a water flow of 105 kg/h. => $\Delta P = 1,8\text{ kPa}$

Combination options with TTC gratings

TTC type	Material	Profile	Bar width [mm]	Bar height [mm]	Bar spacing [mm]	Free cross section [%]	Resulting height [mm]
KST 18.06.65 AN	Aluminium, natural coloured, anodised	T profile	6	18	12	65	180
KSF 18.03.77 AN	Aluminium, natural coloured, anodised	Flat profile	3	18	10	77	180
KSF 18.03.77 VG	Stainless steel, V2A, smoothed top	Flat profile	3	18	10	77	180
LST 18.06.65 AN	Aluminium, natural coloured, anodised	T profile	6	18	12	65	150
LSF 18.03.77 AN	Aluminium, natural coloured, anodised	Flat profile	3	18	10	77	150
LSF 18.03.77 VG	Stainless steel, V2A, smoothed top	Flat profile	3	18	10	77	150
QST 18.06.65 AN	Aluminium, natural coloured, anodised	T profile	6	18	12	65	150
QSF 18.03.77 AN	Aluminium, natural coloured, anodised	Flat profile	3	18	10	77	150
QSF 18.03.77 VG	Stainless steel, V2A, smoothed top	Flat profile	3	18	10	77	150

19.1

Product alternatives

TTC type	Heating	Cooling	Ventilating	System
FHOV	x			2 pipe
FOKV		x		2 pipe
FHKV	x	x		2 pipe or 4 pipe
FHOVZ	x		x	2 pipe
FOKVZ		x	x	2 pipe
FHKVZ	x	x	x	2 pipe or 4 pipe

19.2

For further descriptions ...

... and illustrations regarding the above mentioned gratings please refer to page 7 and also TTC's »Homogeneous Gratings« brochure.

TTC's FHKV Floor Units can be combined with all products in our »TTC Floor Units« technical document.

Air flows | Power consumption | Noise level

	Length 1250			Length 1750			Length 2250			Length 2750		
	V _L	P ₁	L _W	V _L	P ₁	L _W	V _L	P ₁	L _W	V _L	P ₁	L _W
Speed	[m ³ /h]	[W]	dB(A)	[m ³ /h]	[W]	dB(A)	[m ³ /h]	[W]	dB(A)	[m ³ /h]	[W]	dB(A)
20%	99	3	21	118	3	22	204	6	24	223	6	25
40%	227	4	36	272	5	37	471	9	39	515	9	40
60%	356	8	47	426	9	48	737	16	50	807	17	51
80%	484	14	56	580	16	57	1003	29	59	1099	31	60
100%	613	22	60	735	26	61	1270	45	63	13910	49	64

19.3

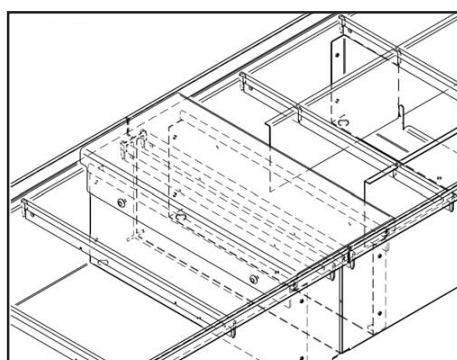

19.4

Centre cover with sound insulation

A centre cover is available for FHKV in banded layouts that pass underneath dry walls.

This is made of robust aluminium plate underneath which a custom-fit sound insulation is inserted. This prevents telephone noise being transferred from room to room.

All components of this centre cover come with a special footfall sound insulation.

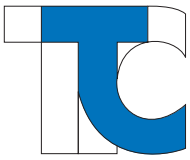

TTC Timmler Technology

Developing innovative solutions for new buildings and redevelopment projects in close co-operation with architects and planners

Assisting architects and planners to develop customized solutions during the planning phase is just one of the strengths of TTC Timmler Technology.

TTC supplies intelligent buildings technology for contemporary residential and work environments: LED lights, innovative air conditioning systems, design-oriented façade components and gratings for both interior and exterior applications. Our know-how and many years experience let you combine modern design, energy efficiency and economic viability. Whatever your technical requirements, we design customized solutions consisting of standard components or tailor-made components, produced to your specifications.

Kind to the environment and economically viable

People and the environment are at the heart of TTC's philosophy. We develop natural air conditioning systems that are both energy and cost efficient.

Multi-functionality Use our know-how to enhance your design

Multi-functionality is a particularly strong point of TTC buildings technology. To name just a few examples:

- LED Lightdesign – As with TTC gratings you can also use TTC Lighttools in our maintenance platforms to create a stunning illumination and to put your design into the »lime-light«. The options TTC Lightdesign is offering are as versatile as your ideas: From Façade space lights, Power LEDs, LED light lines and tiles to wall washers – with individual designs and a wide range of materials we can deliver customized solutions for your projects.
- TTC Modultherm is the ideal system to noiseless air condition whole buildings cost efficiently, using the natural force of gravity.
- TTC Chilled Beams ensure an air conditioning with high comfort an very low noise in working areas. In arrangement with the architect chilled beams add themselves into the design of the ceiling.
- TTC Floorunits with different functionalities of heating, cooling and ventilation provide the free view through space high glass façades. These products combine design with functionality an energy efficiency.
- Homogeneous grating systems allow a seamless transition between the interior and the exterior design of a building. On the inside TTC Under Floor systems provide solutions for all your heating, cooling and ventilation requirements and on the outside they complement the TTC Façade Drainage systems.
- Filigree sun protection systems on the façade provide openness and transparency.

TTC Timmler Technology GmbH

Christian-Schäfer-Str. 8
D-53881 Flamersheim
Tel +49 (0) 2255 921-0
Fax +49 (0) 2255 921-500
info@ttc-technology.eu
www.ttc-technology.eu

